

# BAYER MOBILE LOG PALLETS AND PALLETS

1. Logs and pallets are light and mobile.
  - a. Reduced weight facilitates pallet switching, setup and storage.
  - b. Reduced weight improves accuracy by reducing machine heat and deflection.

## SQUARE PALLET P/N SPT-12.6

1. The square pallet can be used with either the flat pallet clamp or rotary table.
2. The minimum T- slot circle is 6.4 inch diameter.
3. The T- slot width is .5625 inches.
4. They are machined from 6061-T6 aluminum alloy.

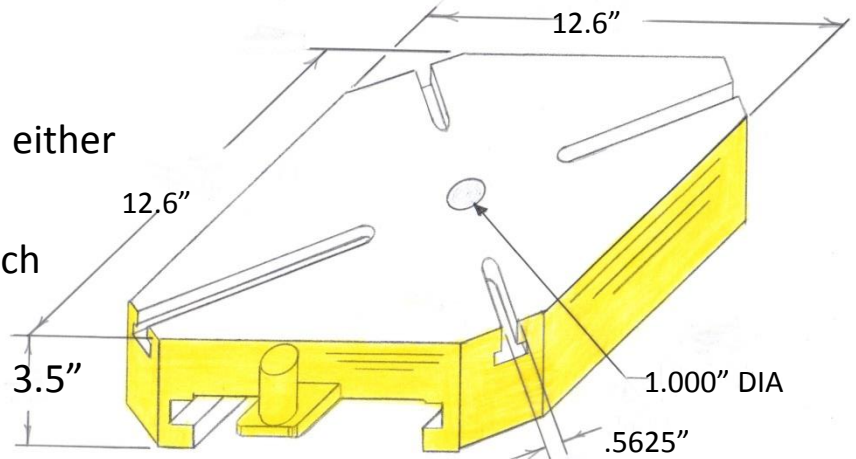

## SQUARE PALLET P/N SP-12.6

Same as above but are supplied without T-slots.

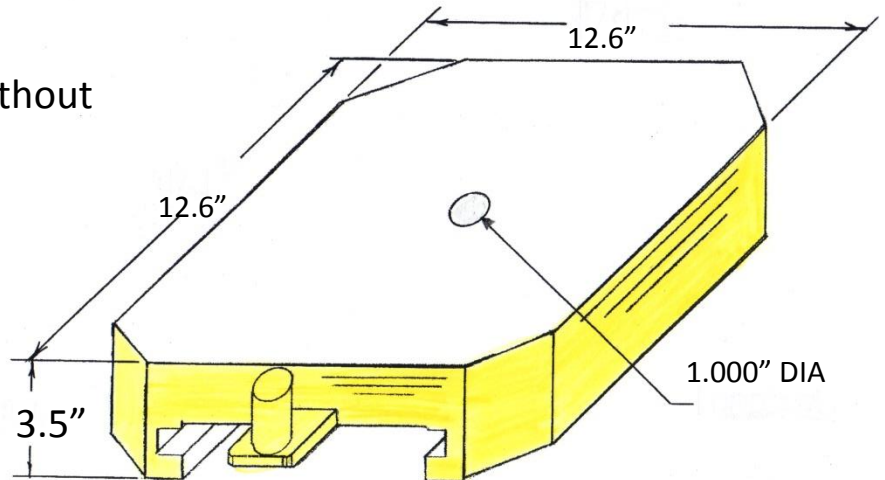

Logs and pallets, except the square pallet, are machined from 7075-T651 aluminum. They are as hard as cold rolled steel.

Bayer fixture patent #8002254

BAYER SYSTEMS 5150 N 24 TH ST, PHOENIX, AZ 85016 TEL 602-448-9409

## X Flat PALLET

P/N	L		P/N	L	
XPK-24	24.00"	WITH KEYS	XP-24	24.00"	KEYS AT 2.000" AND 14.000" ONLY
XPK-32	32.00"	"	XP-32	32.00"	KEYS AT 2.000" AND 18.000" ONLY

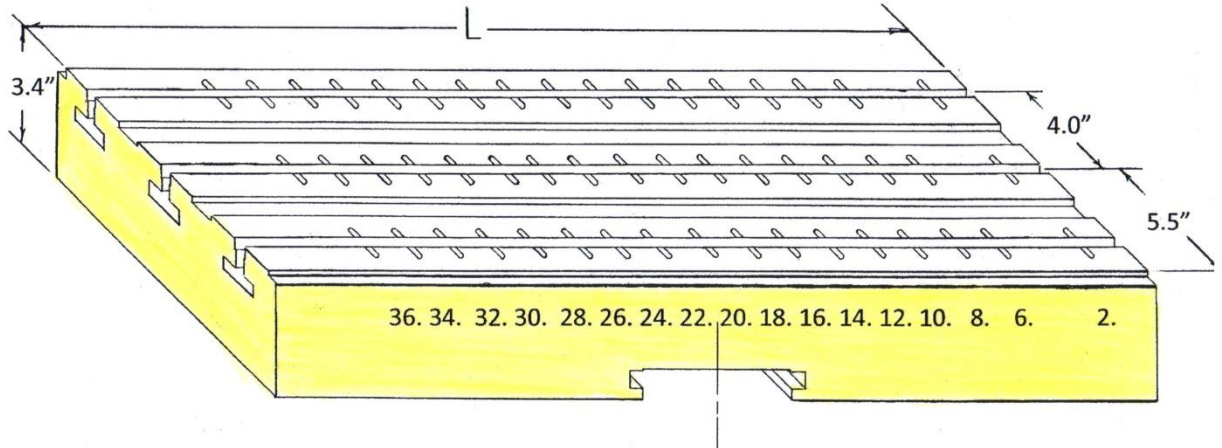

## Y FLAT PALLET

P/N	A	W
YP-20	8.000"	20.00"
YP-24	10.000"	24.00"
YP-32	15.000"	32.00"

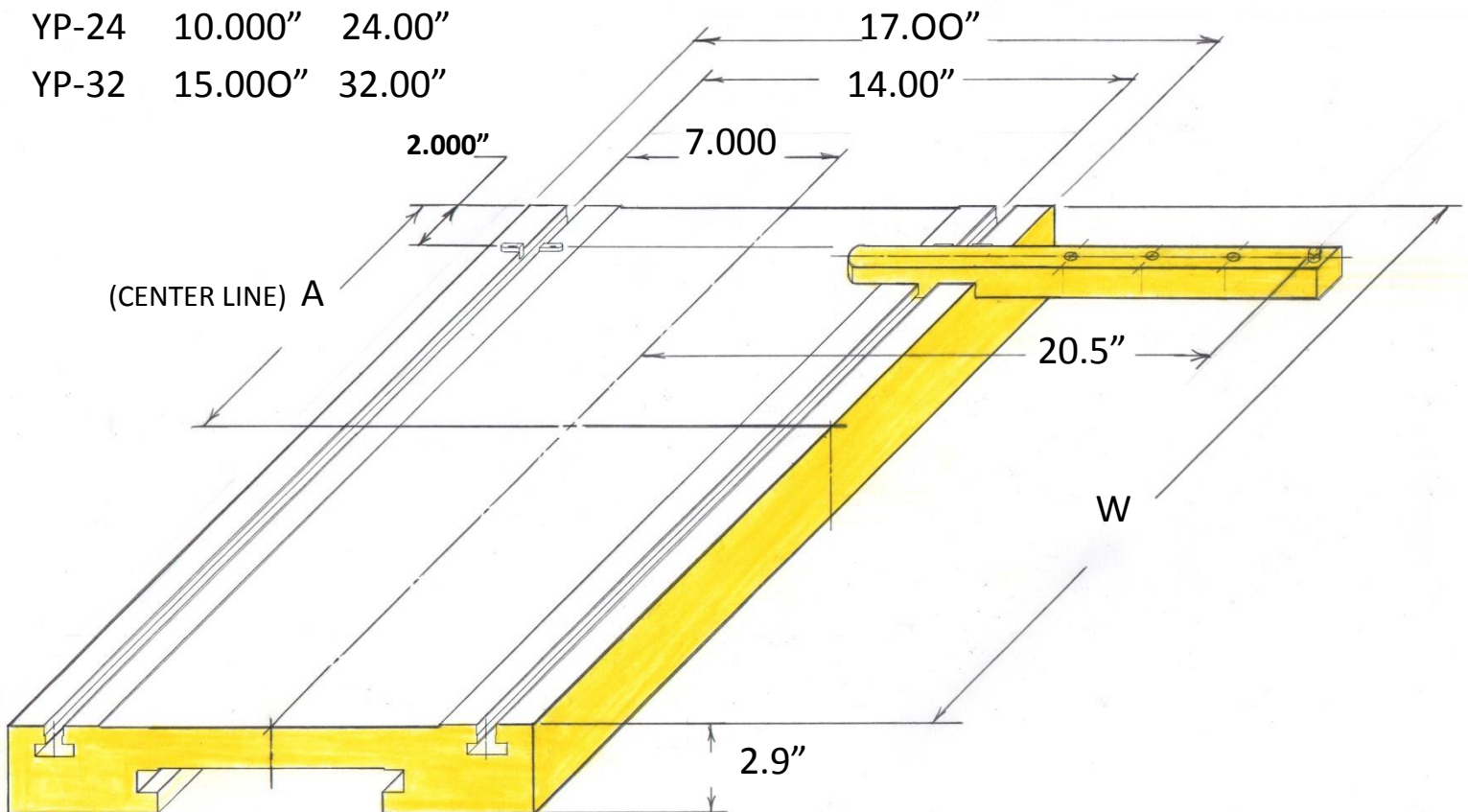

# STANDARD LOG PALLETS

## UNIVERSAL LOG PALLET

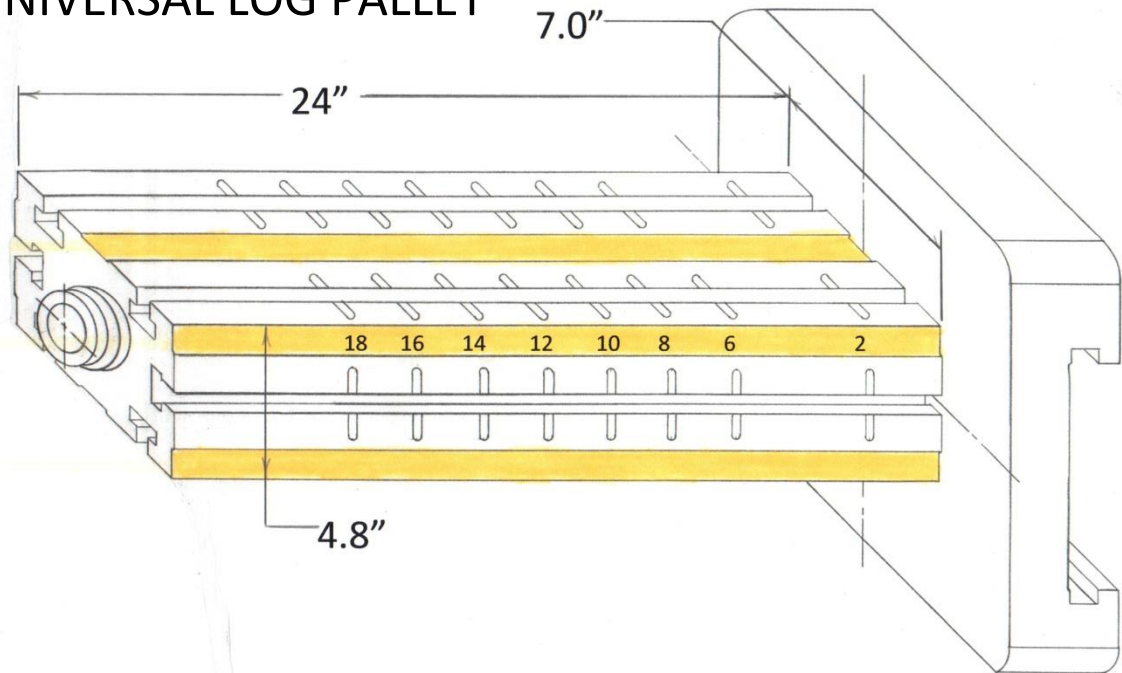

P/N LPK2/1-24 WITH KEYS

P/N LP2/1-24 WITH KEYS AT 2, AND 14"

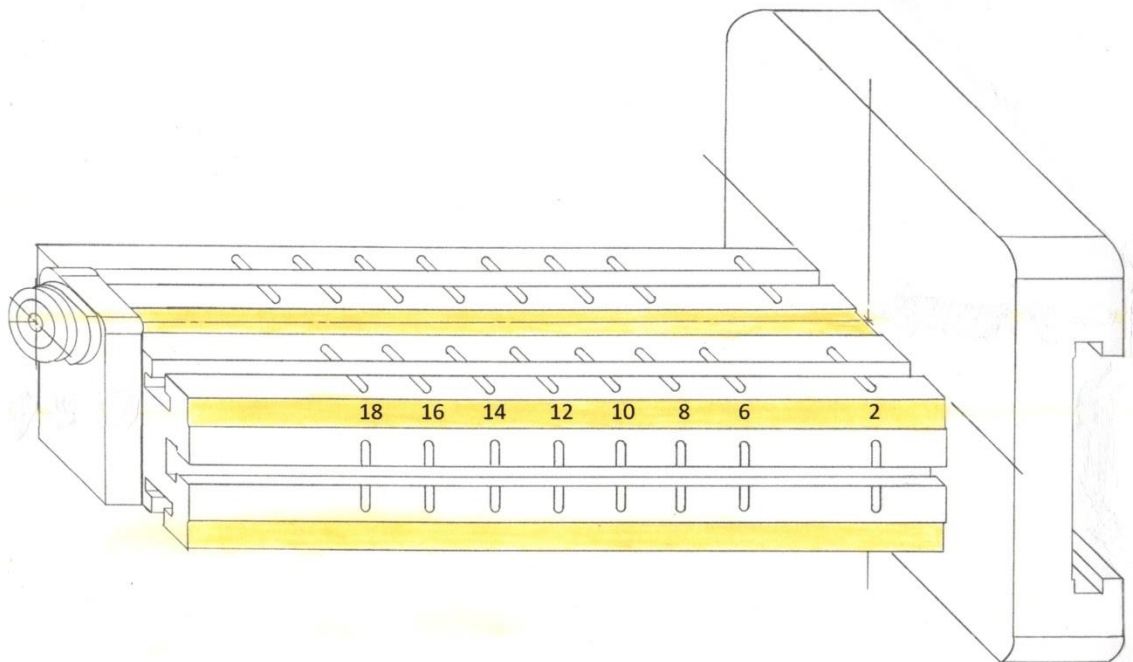

THE UNIVERSAL LOG PALLET MAY BE OFFSET BY USING AN OFFSET EXTENDER.

P/N OFE

# SPECIAL LOG PALLET

## FOUR STATION LOG

P/N            L

LPK4-24    24.00" WITH KEY

LP4-24     24.00" WITH KEYS AT 2.000" AND 14.000" ONLY

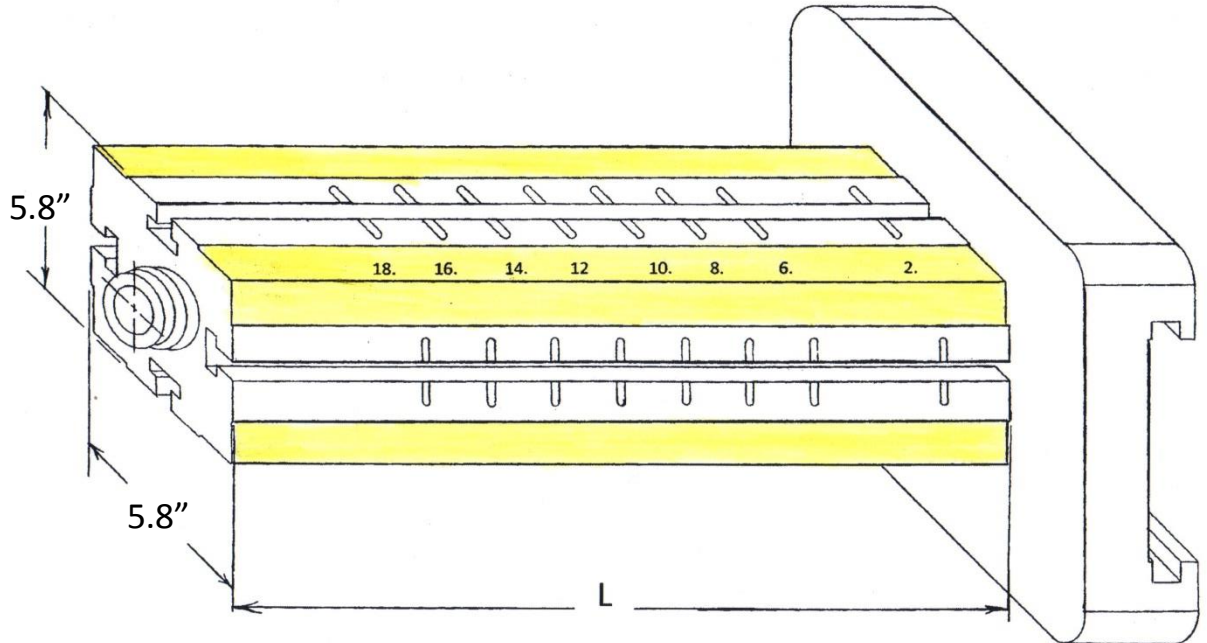

DRAWING SHOWS KEYS AT 2.000" AND 14.000" ONLY

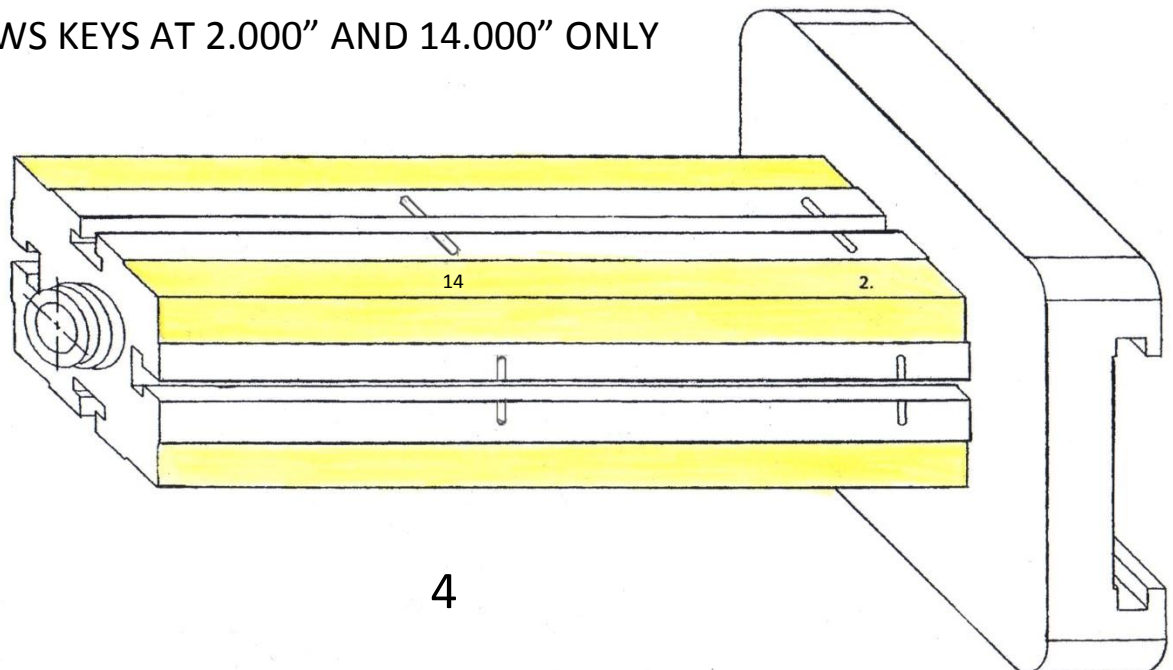

# SPECIAL LOG PALLETS

## SIX STATION LOG PALLET P/N

LPK6-24 24.00" WITH KEYS

LP6-24 24.00" WITH KEYS AT 2.000" AND 14.000" ONLY

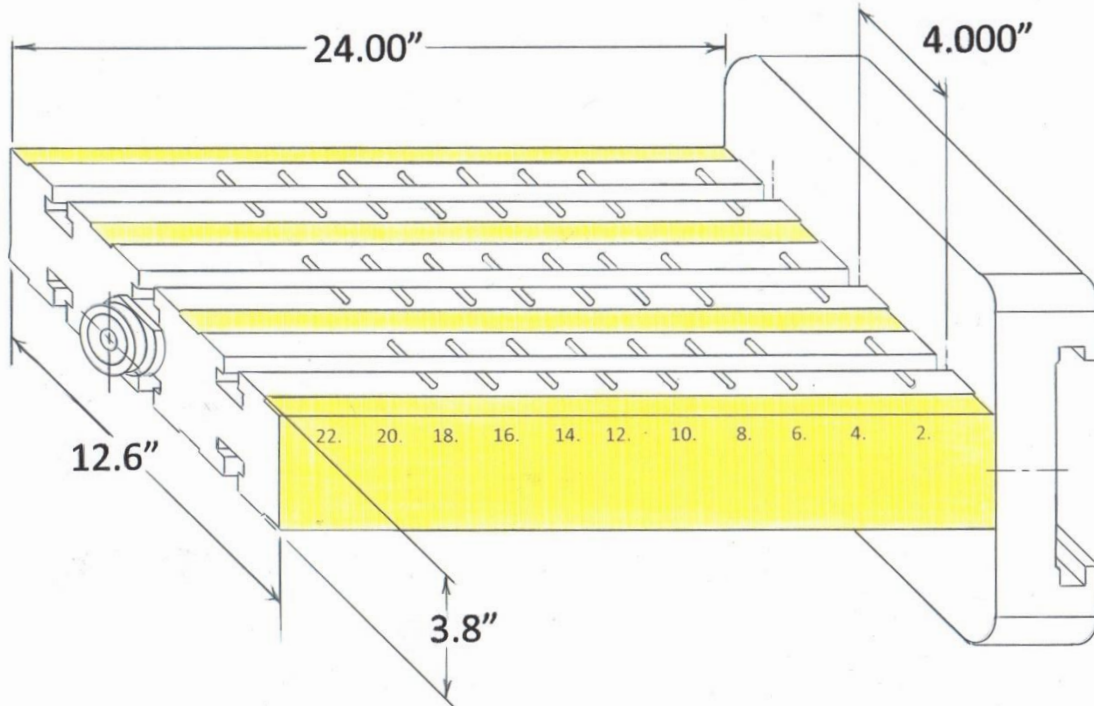

## THREE STATION OFF SET LOG PALLET

LOPK3-24 24.00" WITH KEYS

LOP3-24 24.00" WITH KEYS AT 2.000" AND 14.000" ONLY

